

# INSTALLATION GUIDE

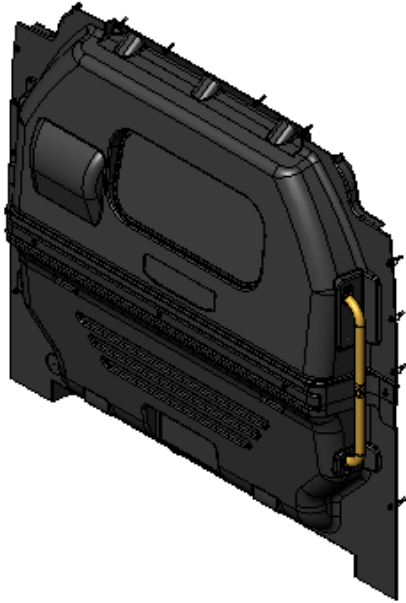

**3310-RP**

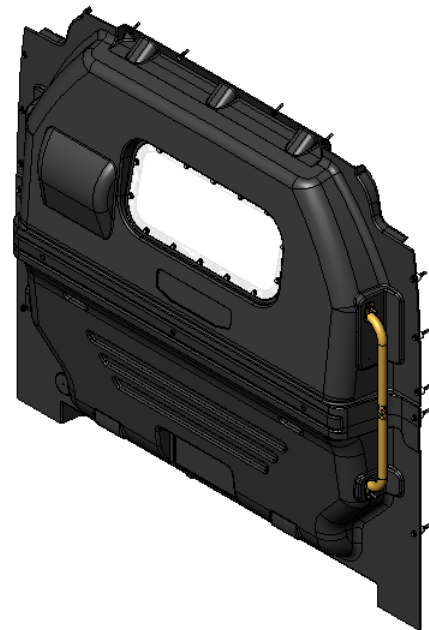

**3320-RP**

**Composite Partition**  
RAM Promaster



# QUICK START GUIDE

## Phase 1 - Assembly

<input type="checkbox"/> 1.1 Setup.....	3 - 4
<input type="checkbox"/> 1.2 Partition Assembly.....	5

## Phase 2 - Install

<input type="checkbox"/> 2.1 Vehicle Preparation.....	6 - 8
<input type="checkbox"/> 2.2 Partition Installation.....	9 - 10
<input type="checkbox"/> 2.3 Handle Installation.....	11

# REQUIRED ITEMS

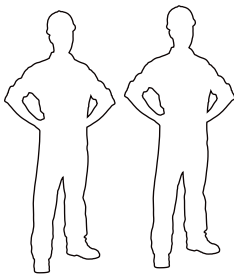

**2**  
**PERSONS**

- Cordless Impact
- Cordless Drill
- Marker
- Plusnut Tool
- Tape Measure
- 3/8" Drill Bit
- 7/16" Socket
- 1/2" Socket
- 1" Hole Saw
- 9/16" Wrench

# PHASE 1 – ASSEMBLY

## 1.1 SETUP

1.1.1 Unpack components; compare with the bill of materials.

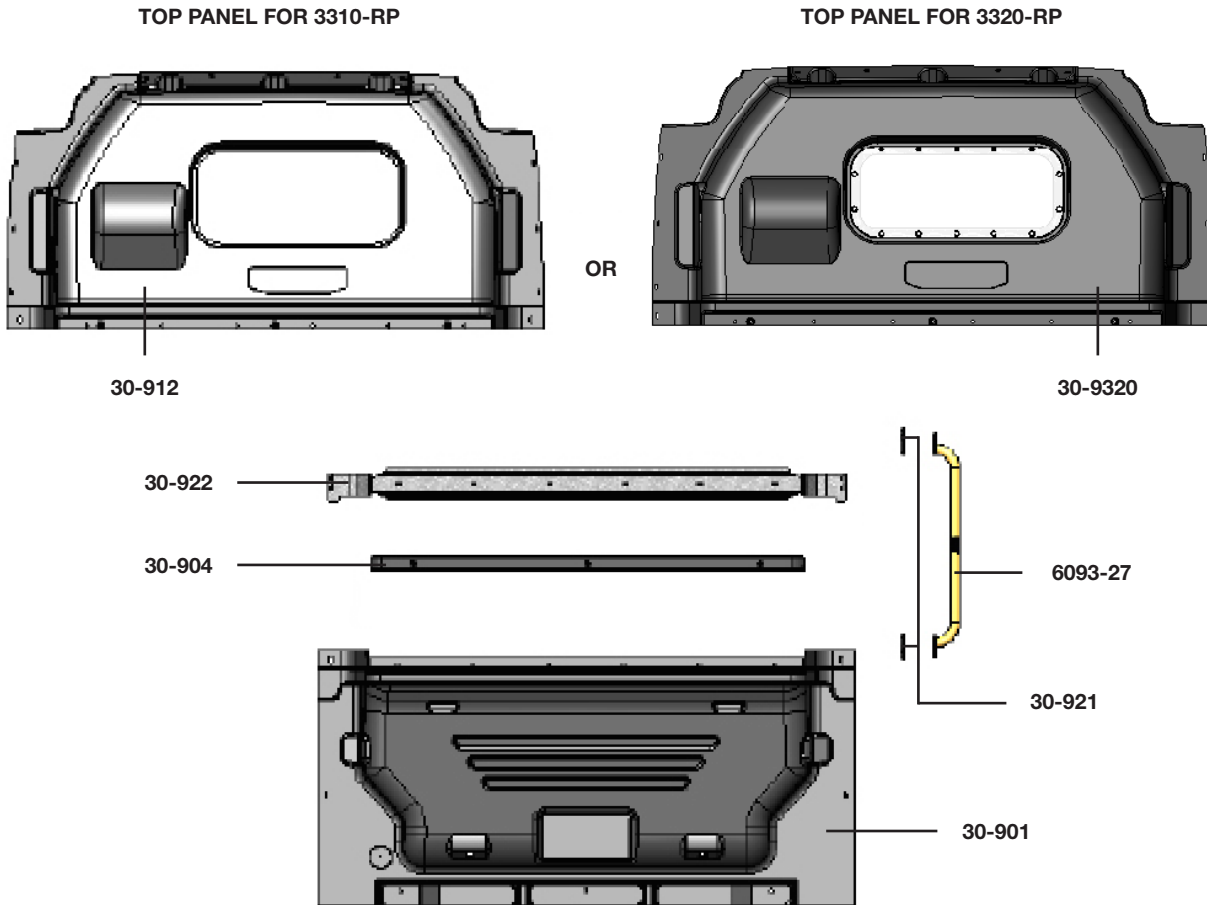

1.1.2 Verify all parts are present.

Item No.	Description	Qty.
30-901	Bottom Panel	1
30-904	Bolt Cap	1
30-912 OR 30-9320	Top Panel	1
30-922	Support	1
30-921	Handle Plate	2
6093-27	Large Grab Handle	1
94-5017	Assembly Fastener Kit	1
96-3041	Install Fastener Kit	1

1.1.3 Identify the **Assembly** and **Installation** fastener bags.

94-5017



Hardware Assembly

x6

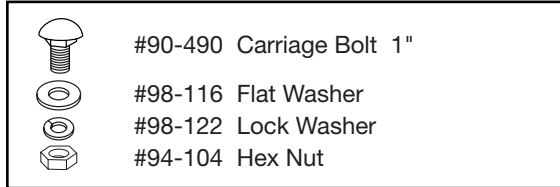

x3

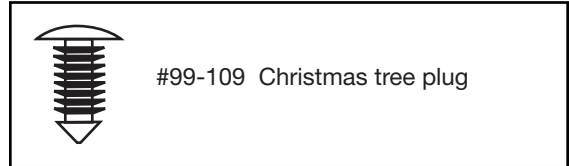

96-3041

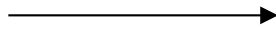

Hardware Assembly

x8



x2

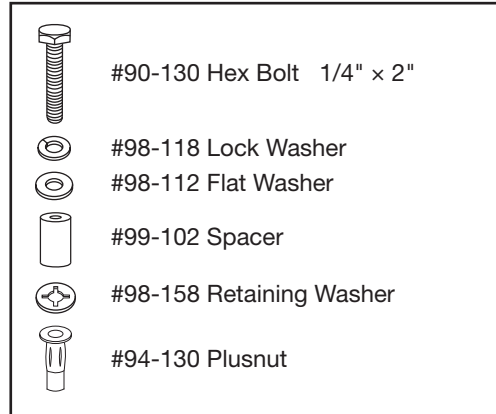

x5



x1

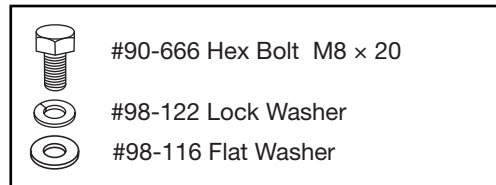

# PHASE 1 – ASSEMBLY

## 1.2 PARTITION ASSEMBLY

1.2.1 Attach the top and bottom panel with support bracket.

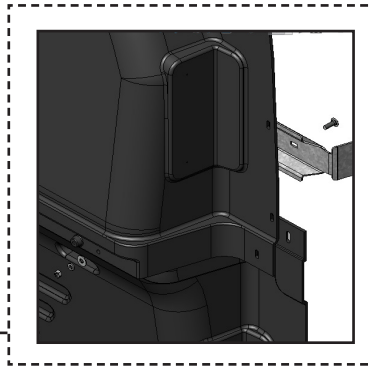
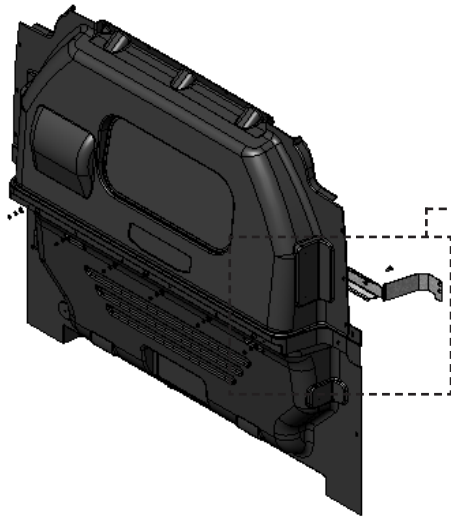

### TOOLS

- Cordless Impact
- 1/2" Socket

### HARDWARE USED

6x



#90-490 Carriage Bolt 1"



#98-116 Flat Washer



#98-122 Lock Washer



#94-104 Hex Nut

1.2.2 Plug the Bolt cap to the partition using Christmas tree plug.

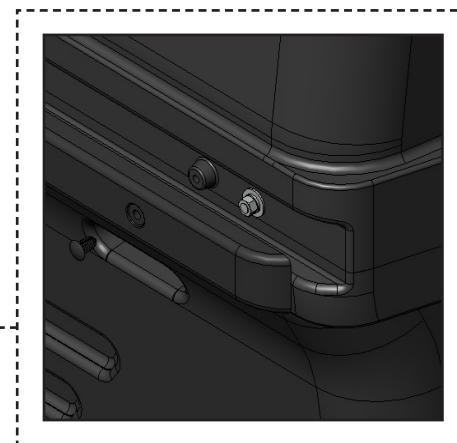
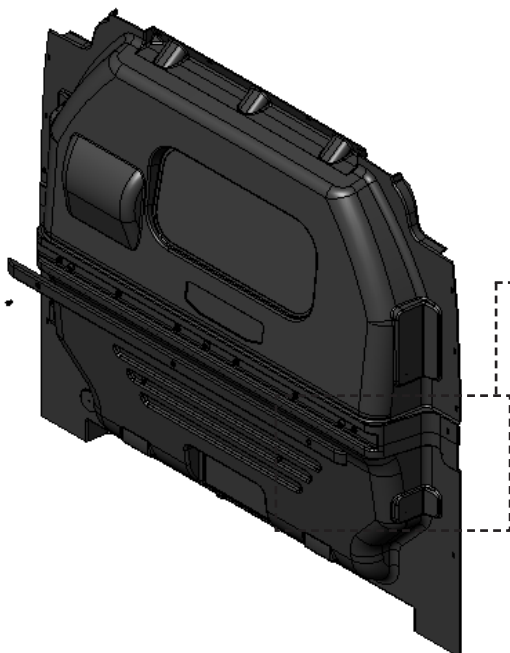

### HARDWARE USED

3x



#99-109 Christmas tree plug

# PHASE 2 – INSTALL

## 2.1 VEHICLE PREPARATION

2.1.1 Lift the partition on the van and put it in place.

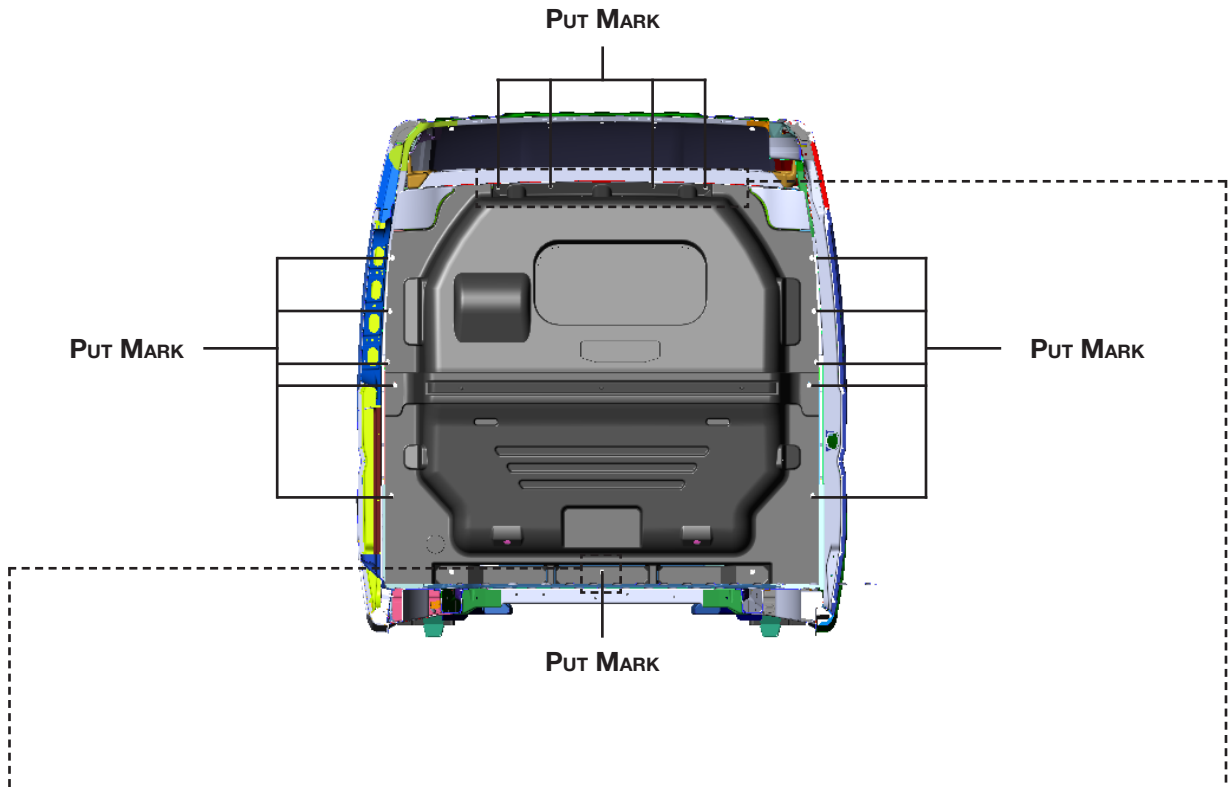

Attach plusnut on the center hole in the floor.



**TOOLS**  
☐ Plusnut Tool

**HARDWARE USED**

**1x**

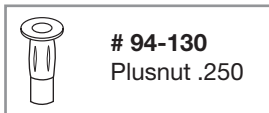

Lift the partition on the side, then drill the 4 marks on the top or enlarge the holes using 3/8" drill bit.



**TOOLS**

- ☐ Cordless Drill
- ☐ 3/8" Drill Bit or Step Drill

Cut or drill the plastic cover through the 4 holes, then Attach plusnuts in the 4 holes.



**TOOLS**

- ☐ Plusnut Tool
- ☐ 1" Hole Saw or Knife

**HARDWARE USED**

**4x**

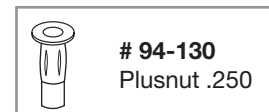

2.1.2 Removing screw and attaching plusnut on the van.

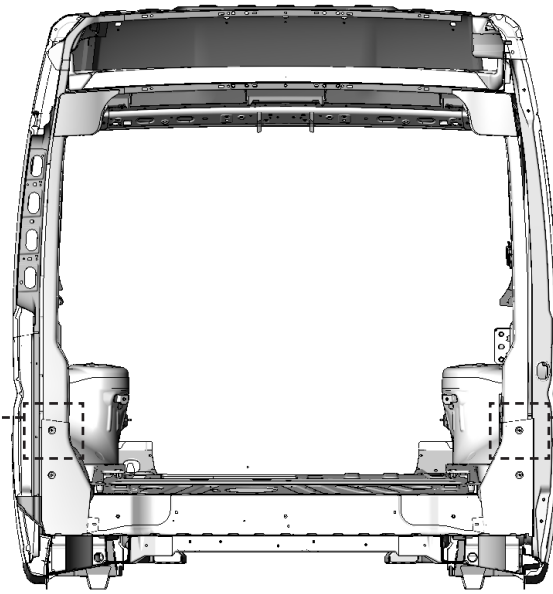

Remove the factory screws.

**TOOLS**

- Phillips Head Drive Bit
- Cordless Drill



Cut the plastic with a 1-1/2" hole saw.

**TOOLS**

- Cordless Drill
- 1-1/2" Hole Saw



Attach plusnuts in the 2 holes.

**TOOLS**

- Plusnut Tool

**HARDWARE USED**

**2x**



# 94-130  
Plusnut .250

### 2.1.3 Driver and passenger sides preparation.

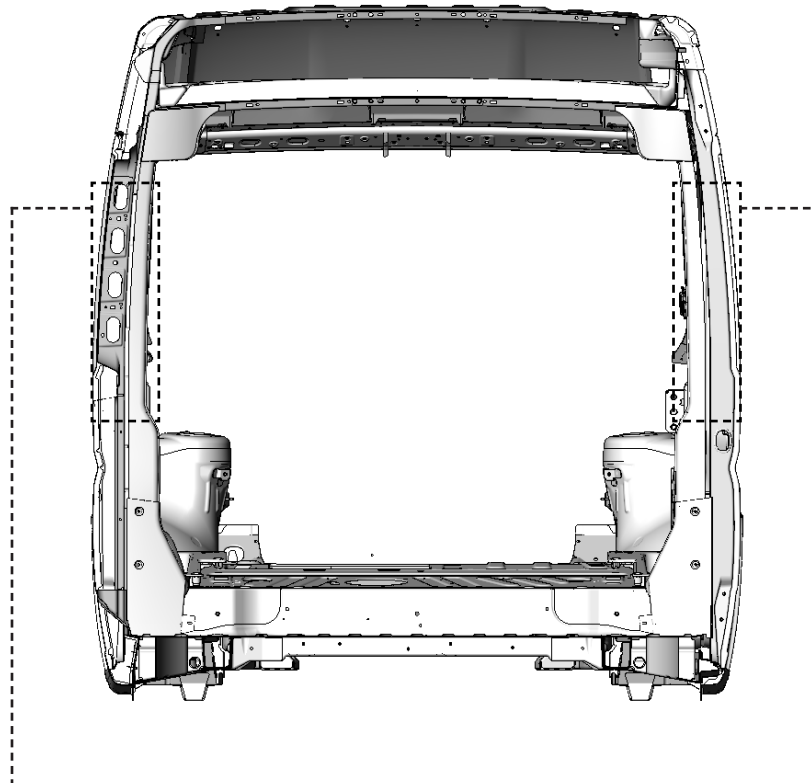

Drill through the plastic using the hole saw.

#### TOOLS

- Cordless Drill
- 1" Hole Saw



Enlarge the holes if the plusnuts don't fit and make new holes if they don't align with the panel on the van.

#### TOOLS

- Cordless Drill
- 3/8" Drill Bit or Step Drill



Attach plusnuts in the 6 holes.

#### TOOLS

- Plusnut Tool

#### HARDWARE USED

**6x**



# 94-130  
Plusnut .250



# PHASE 2 – INSTALLATION

## 2.2 PARTITION INSTALLATION

2.2.1 Lift and place the partition back on the van, then attach the partition to the

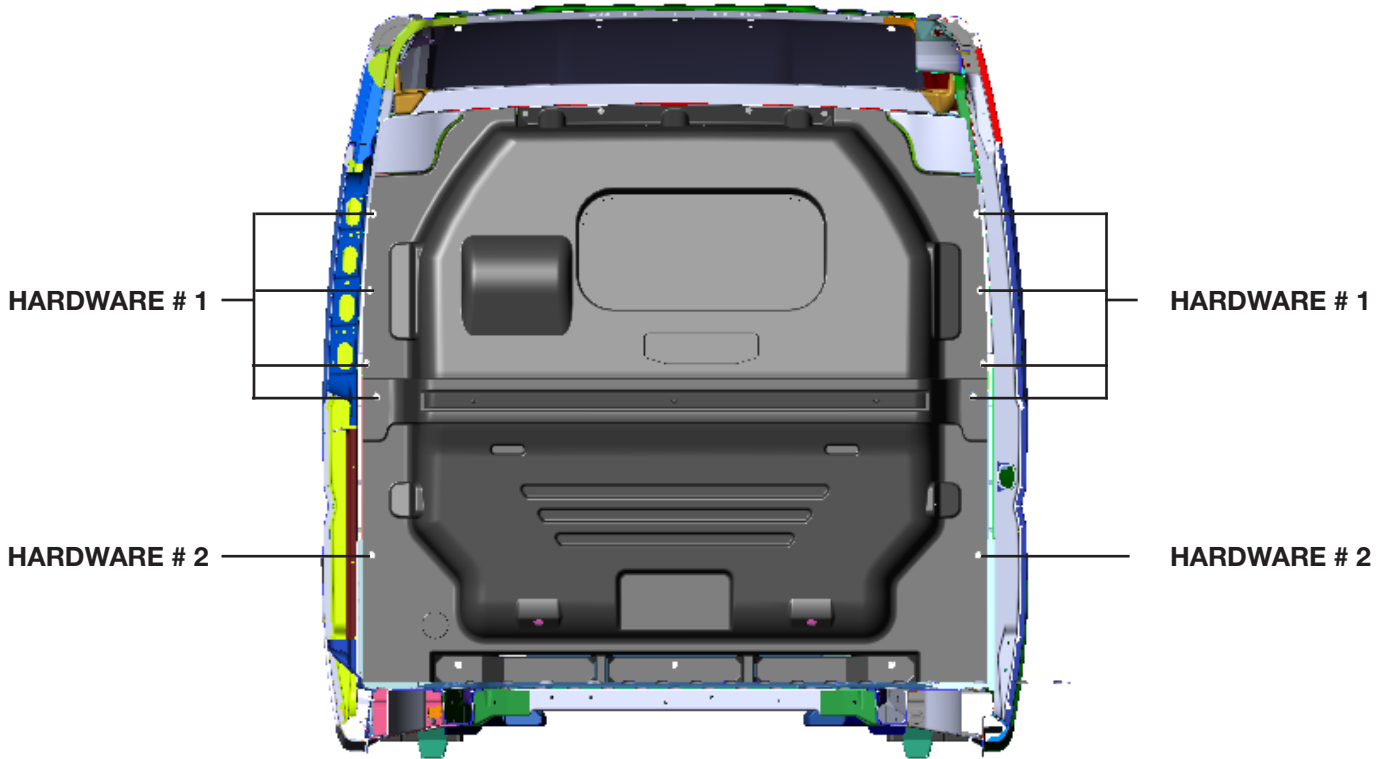





### HARDWARE # 1

#### TOOLS

- Cordless Impact
- 7/16" Socket

#### HARDWARE USED

8x

-  #90-122 Hex Bolt 1/4" x 1-1/2"
-  #98-118 Lock Washer
-  #98-112 Flat Washer
-  #98-161 Spacer
-  #98-158 Retaining Washer





### HARDWARE # 2

#### TOOLS

- Cordless Impact
- 7/16" Socket

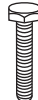
#### HARDWARE USED

2x

-  #90-130 Hex Bolt 1/4" x 2"
-  #98-118 Lock Washer
-  #98-112 Flat Washer
-  #99-102 Spacer
-  #98-158 Retaining Washer

2.2.2 Bolt the top and bottom of the partition to the van.

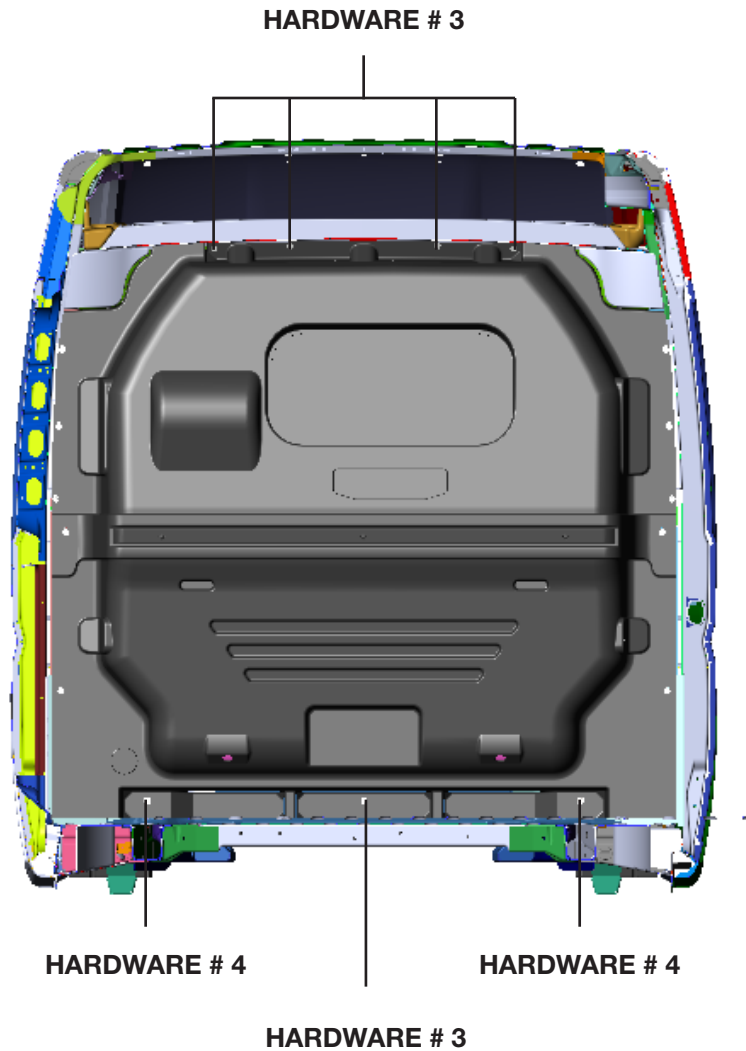



**HARDWARE # 3**

**TOOLS**

- Cordless Impact
- 7/16" Socket

**HARDWARE USED**

**5x**

	#90-114 Hex Bolt 1/4" x 1"
	#98-118 Lock Washer
	#98-112 Flat Washer



**HARDWARE # 4**

**TOOLS**

- Cordless Impact
- 13mm Socket

**HARDWARE USED**

**2x**

	#90-666 Hex Bolt M8 x 20
	#98-122 Lock Washer
	#98-116 Flat Washer

# PHASE 2 – INSTALLATION

## 2.3 HANDLE INSTALLATION

2.3.1 Attach the handle on the passenger side of the van.

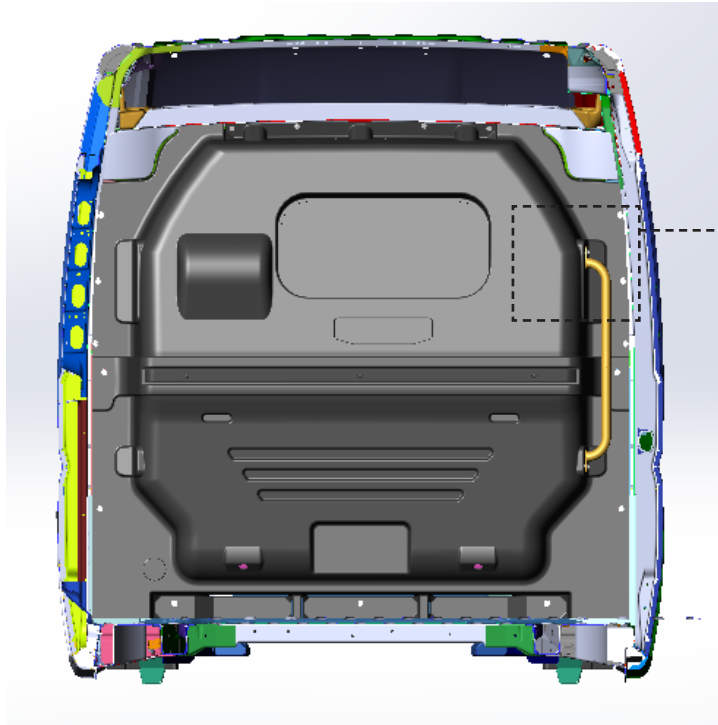

INSIDE

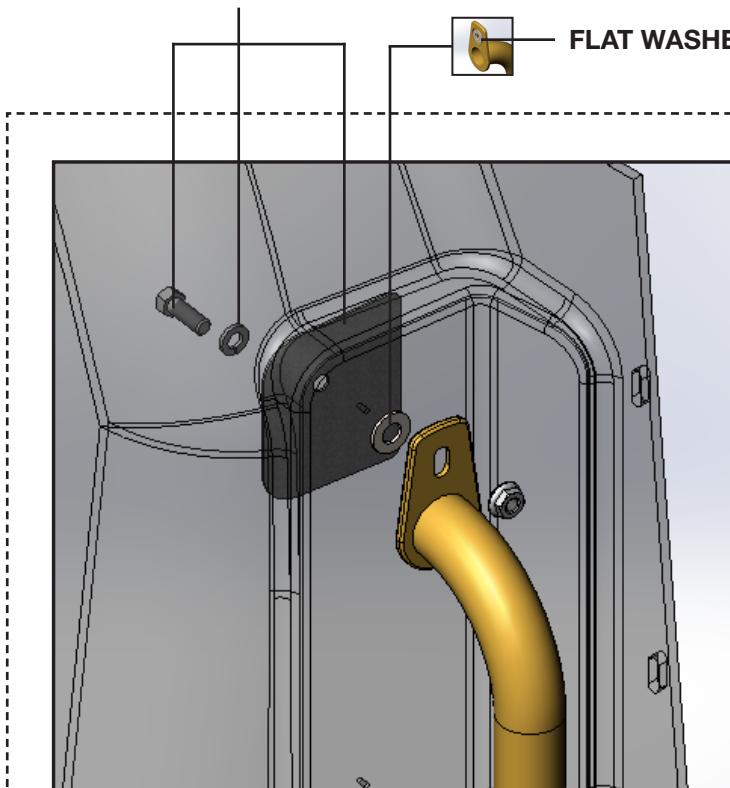

**NOTE:** You need to enlarge the hole in the partition panel.

### TOOLS

- Cordless Impact
- Cordless Drill
- 1/2" Socket
- 3/8" Drill Bit

### HARDWARE USED

**2x** GRAB HANDLE FASTENER KIT



#90-206 Hex Bolt 5/16" x 7/8"



#98-122 Lock Washer



#98-116 Flat Washer



#94-116 Serrated Nut

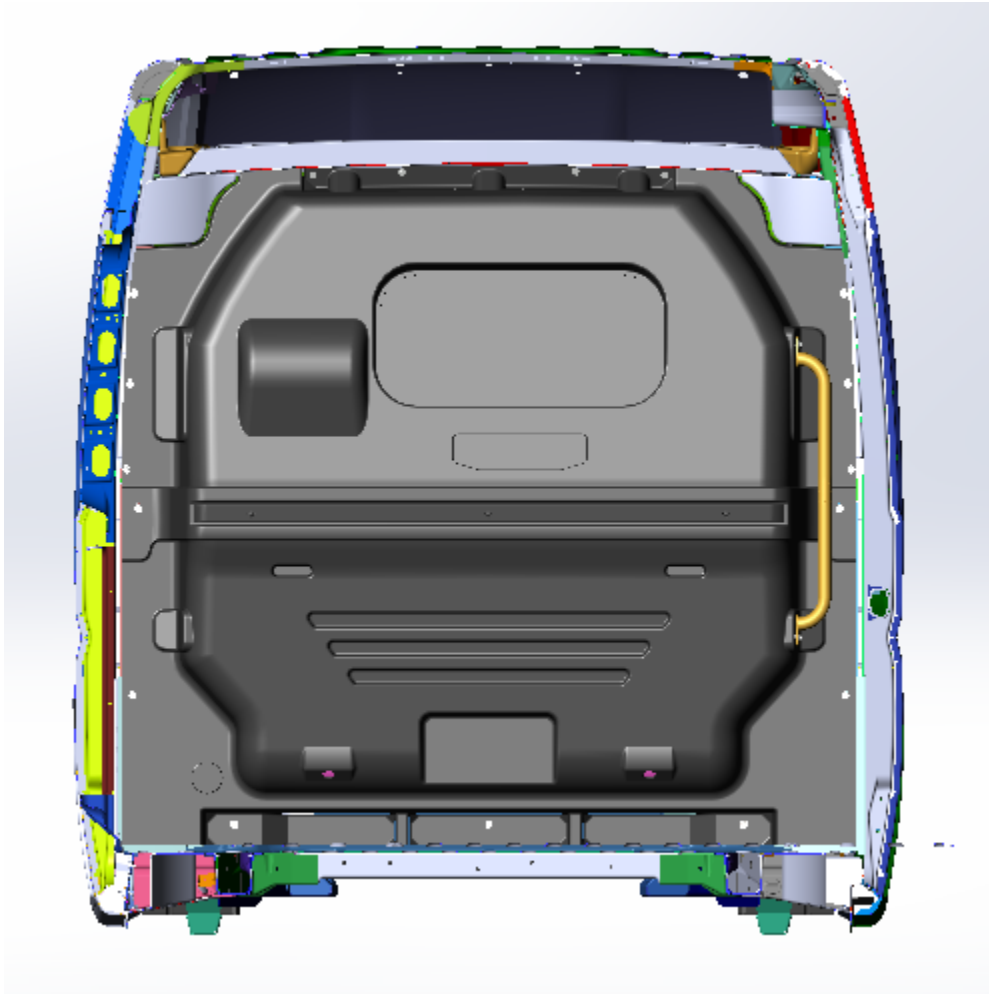

**“You have successfully installed your  
Partition**

**Thank you for doing business with us.”**

For any feedback or suggestions you may have, please contact: [cs@rangerdesign.com](mailto:cs@rangerdesign.com)

