

INSTALLATION GUIDE

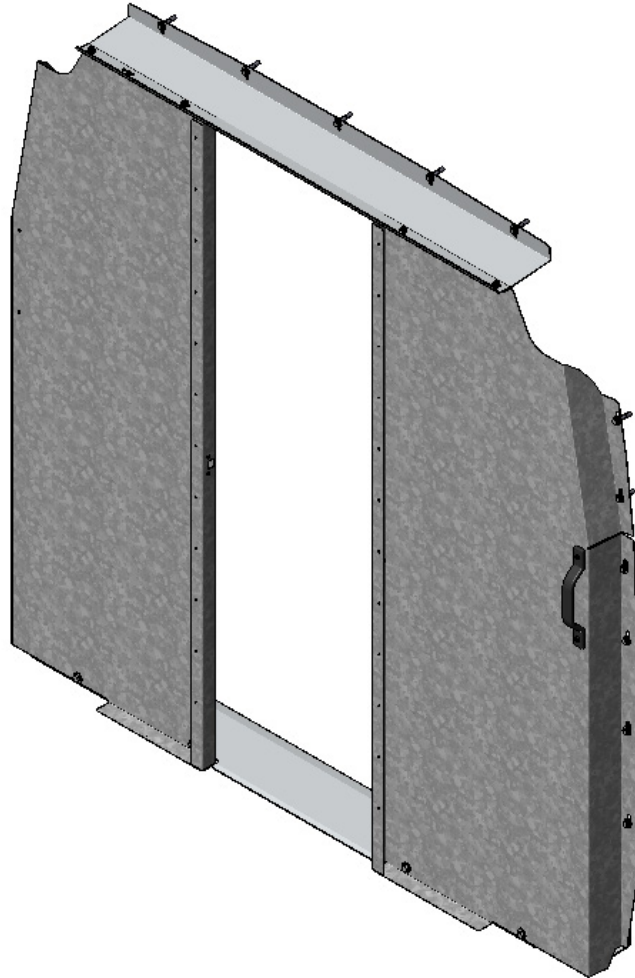

C24-DL STRAIGHT PARTITION

Sprinter Partition (Walk-Through, Steel)



QUICK START GUIDE

Phase 1 - Assembly

| | |
|--|-------|
| <input type="checkbox"/> 1.1 Setup..... | 3 - 4 |
| <input type="checkbox"/> 1.2 Partition assembly..... | 5 |

Phase 2 - Installation

| | |
|---|--------|
| <input type="checkbox"/> 2.1 Tips on how to attach a plusnut..... | 6 |
| <input type="checkbox"/> 2.2 Vehicle preparation..... | 7 |
| <input type="checkbox"/> 2.3 Straight partition installation..... | 7 - 13 |

REQUIRED ITEMS

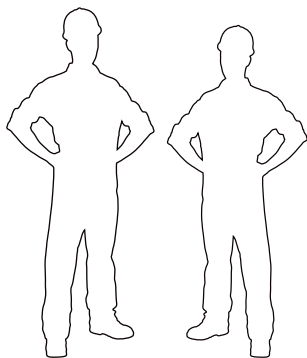

2
PERSONS

- Cordless Impact
- Cordless Drill
- Cutter
- Mallet
- Plusnut Tool
- Tape Measure
- T40 Torque Bit
- 3/8" Drill Bit
- 7/16" Socket
- 1/2" Socket
- 9/16" Wrench
- 3/16" Driver Bit

PHASE 1 – ASSEMBLY

1.1 SETUP

1.1.1 Unpack components; compare with the bill of materials.

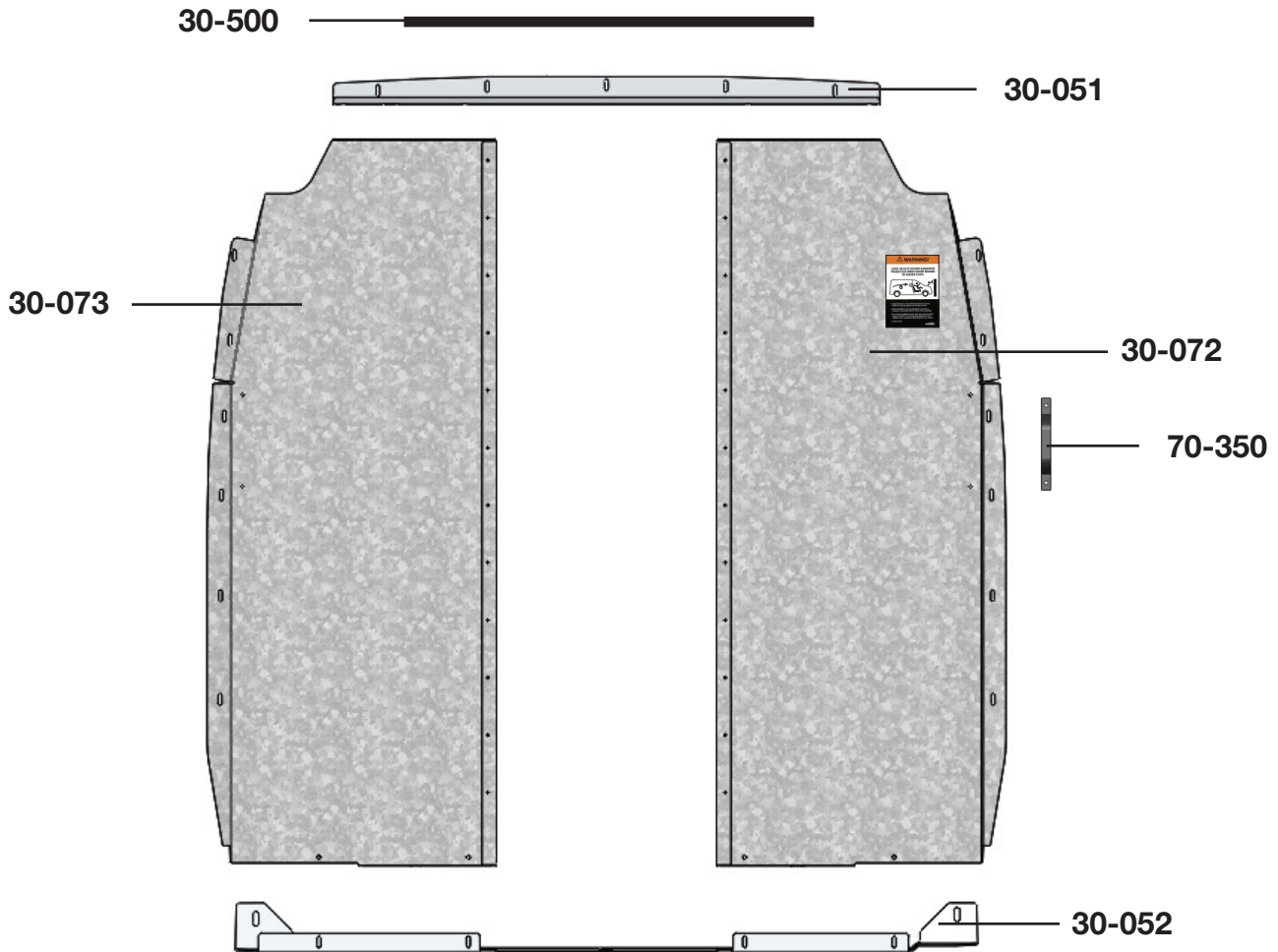

1.1.2 Verify all parts are present.

| Item No. | Description | Qty. |
|----------|-----------------------------|------|
| 30-051 | Top Bracket | 1 |
| 30-052 | Floor Bracket | 1 |
| 30-072 | Passenger Side Panel | 1 |
| 30-073 | Driver Side Panel | 1 |
| 30-500 | Edge Trim (QTY in Inches) | 45 |
| 70-350 | Grab Handle | 1 |
| 79-932 | Warning Label (Bilingual) | 1 |
| 94-3001 | Assembly Fastener Bag | 1 |
| 94-6093 | Assembly Fastener Bag | 1 |
| 96-3001 | Installation Fastener Bag | 1 |



1.1.3 Identify the **Assembly** and **Installation** fastener bags.

94-3001 Fastener Bag →



| | | | |
|-----------|---|-----------------|--|
| 4x |  | # 90-200 | Hex Bolt 5/16"-18 x 1/2" GR-5 ZINC |
| 4x |  | # 90-204 | Hex Bolt 5/16"-18 x 3/4" GR-5 ZINC |
| 8x |  | # 94-116 | Serrated Nut 5/16"-18 ZINC |
| 8x |  | # 98-116 | Flat Washer 5/16", 7/8" OD ZINC |

Hardware Assembly

4x

| | |
|---|-------------------------------|
|  | #90-200 Hex Bolt 5/16" x 1/2" |
|  | #98-116 Flat Washer |
|  | #94-116 Serrated Nut |

4x



| | |
|---|-------------------------------|
|  | #90-204 Hex Bolt 5/16" x 3/4" |
|  | #98-116 Flat Washer |
|  | #94-116 Serrated Nut |

94-6093 Fastener Bag →

| | | | |
|-----------|---|-----------------|---------------------------------|
| 2x |  | # 90-893 | Cap Screw 1/4" x 3/4" |
| 2x |  | # 94-112 | Serrated Nut 1/4"-20 ZINC |

Hardware Assembly

2x

| | |
|---|-------------------------------|
|  | #90-893 Cap Screw 1/4" x 3/4" |
|  | #94-112 Serrated Nut |

96-3001 Fastener Bag →

| | | | |
|------------|---|-----------------|---|
| 17x |  | # 90-118 | Hex Bolt 1/4"-20 x 1-1/4" GR-5 ZINC |
| 17x |  | # 94-130 | Plusnut .250 |
| 17x |  | # 98-112 | Flat Washer 1/4", 3/4" OD ZINC |
| 17x |  | # 98-118 | Lock Washer Regular 1/4" ZINC |

Hardware Assembly

17x

| | |
|--|--------------------------------|
|  | #90-118 Hex Bolt 1/4" x 1-1/4" |
|  | #98-118 Lock Washer |
|  | #98-112 Flat Washer |
|  | #94-130 Plusnut .250 |

PHASE 1 – ASSEMBLY

1.2 PARTITION ASSEMBLY

1.2.1 Remove all the PVC from all the parts, then attach the grab handle on the passenger side panel.

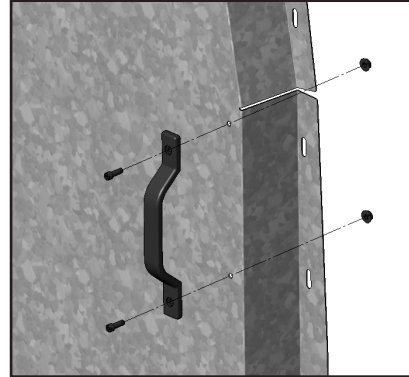
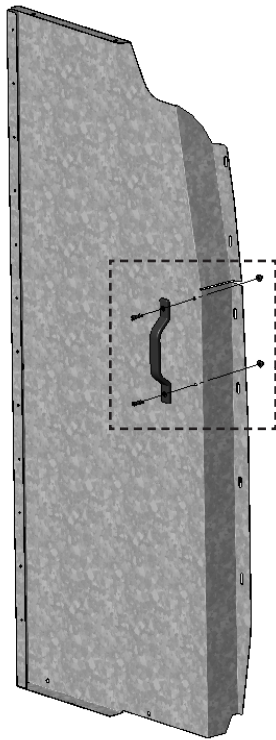

TOOLS

- Cordless Impact
- 3/16" Driver Bit

HARDWARE USED

2x



#90-893 Cap Screw 1/4" x 3/4"



#94-112 Serrated Nut

1.2.2 Attach the edge trims on these locations.

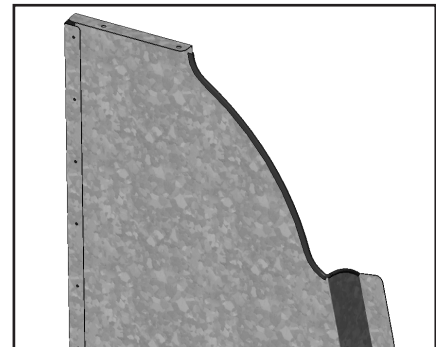
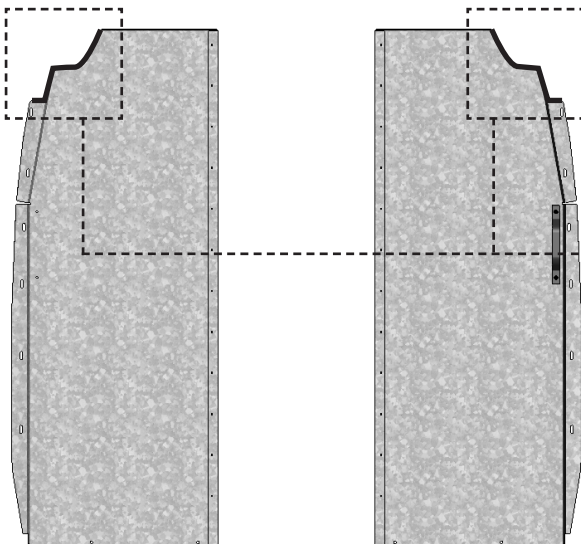

TOOLS

- Mallet
- Cutter

PHASE 2 – INSTALLATION

2.1 TIPS ON HOW TO ATTACH A PLUSNUT

2.1.1 Attach the plusnut using the plusnut gun.

TIPS: Put the plusnut on the plusnut gun, then attach the plusnut in the hole by turning the gun forward until the plusnut locks, then remove the gun by turning in reverse.

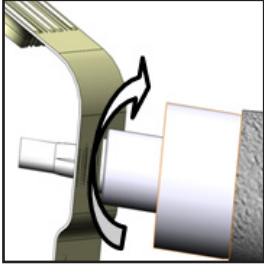

FORWARD

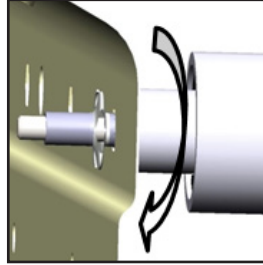

REVERSE

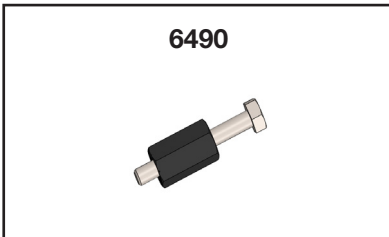

2.1.2 Attach the plusnut using the 6490 plusnut tool.

NOTE: The hardware used for the 6490 plusnut tool is not included in the fastener bag. The 6490 plusnut tool can be ordered separately upon demand at no charge.



6490

HARDWARE USED

-  Flat washer 1/4"
-  Flat washer 1/4" BS x 3/4" OD

TOOLS

- Cordless Impact
- 7/16" Socket
- 9/16" Wrench

TIPS STEP 1:

Assemble the 6490 plusnut tool with the hardware needed, plusnut and the 9/16" wrench as shown.



TIPS STEP 2:

Attach the plusnut in the hole by turning the bolt forward using an impact with a 7/16" socket until the plusnut locks, then remove the bolt by turning the impact in reverse.

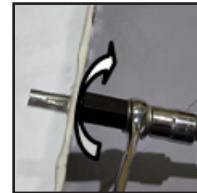

FORWARD



REVERSE

PHASE 2 – INSTALLATION

2.2 VEHICLE PREPARATION

2.2.1 Floor preparation.

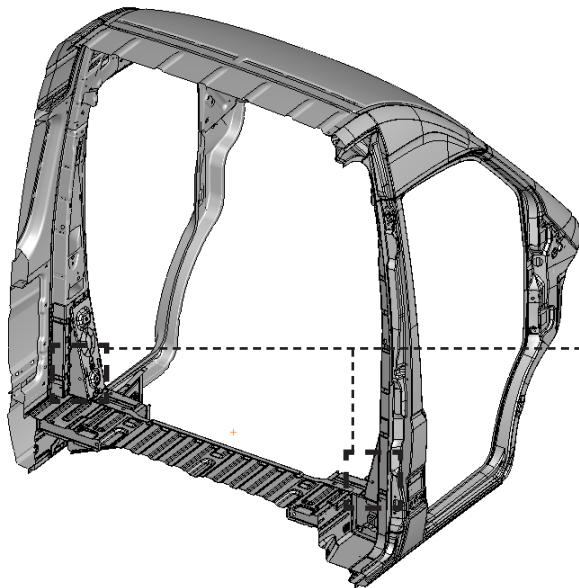

Remove the two D-rings in the pillars, for re-use.

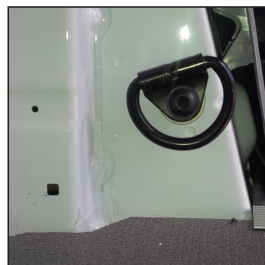

TOOLS

- Cordless Impact
- T40 Torque Bit

PHASE 2 – INSTALLATION

2.3 STRAIGHT PARTITION INSTALLATION

2.3.1 Floor bracket installation.

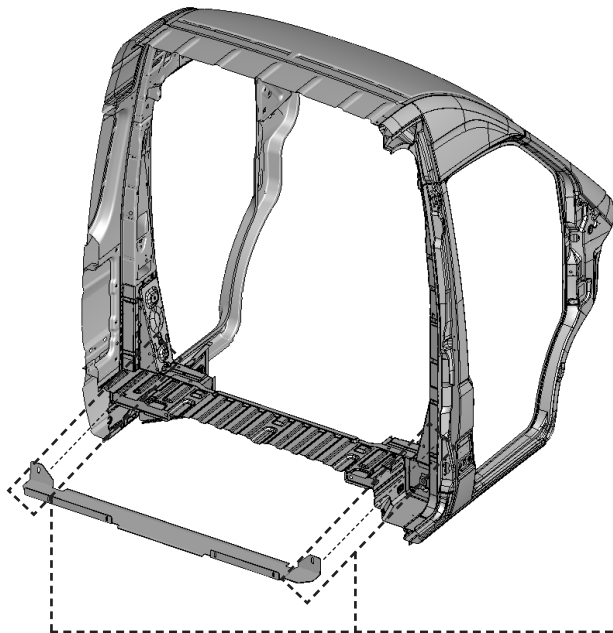

Attach the floor bracket to the floor re-using the 2 D-ring bolts.



TOOLS

- Cordless Impact
- T40 Torque Bit

HARDWARE USED

2x

Use the D-ring bolt

2.3.2 Attaching plusnuts.

NOTE: Check if the holes of the partition align with the holes of the van.

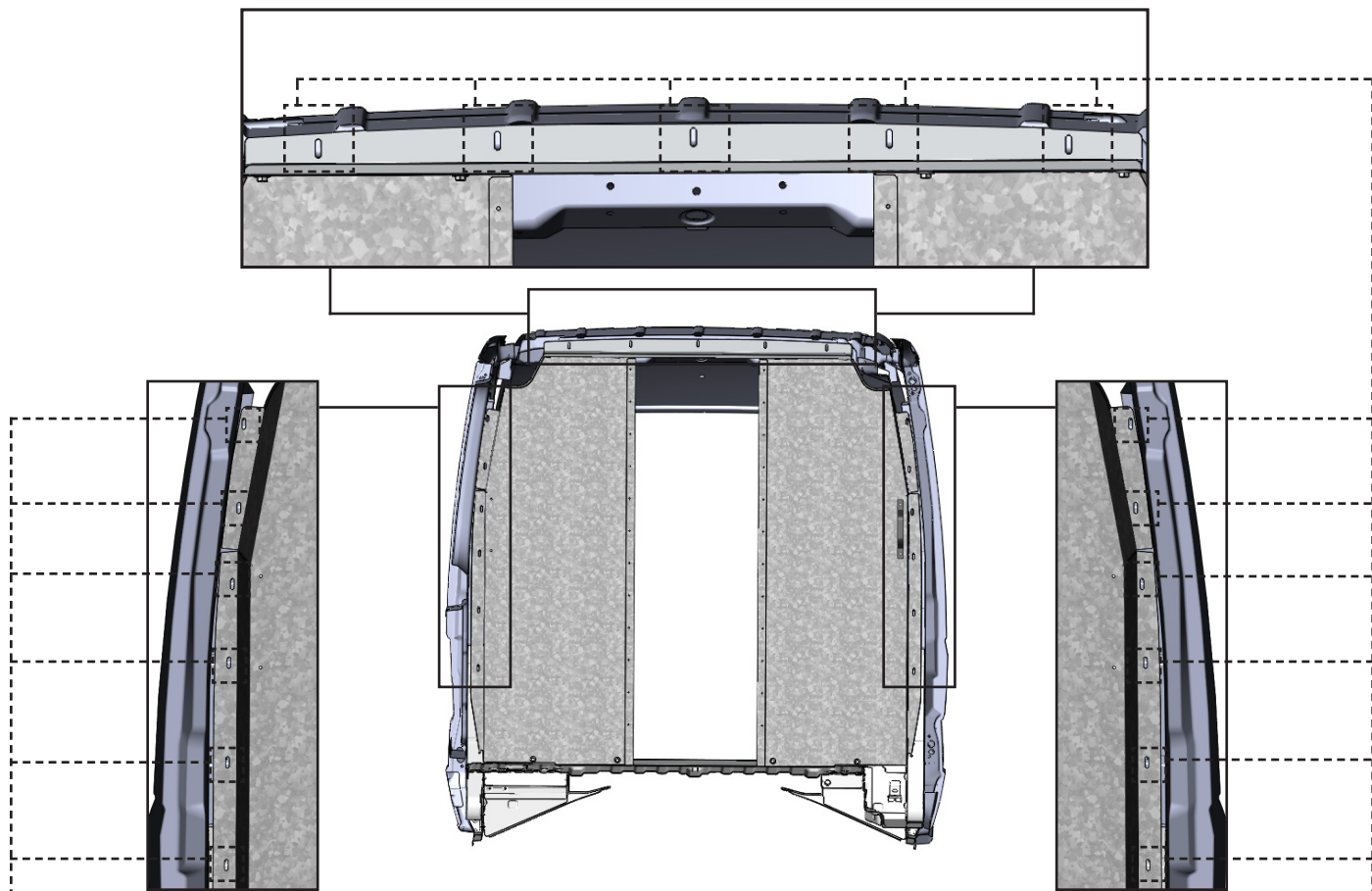

Put the assembled partition in place, then mark all the holes through the van.

- NOTE:**
- For the B-pillar plastic cover and wood floor use 1" hole saw to drill a hole in the B-pillar plastic cover or wood floor, then drill 3/8" hole in the van.
 - Enlarge all the holes in the van that align with the holes of the partition using 3/8" drill bit or step drill.

TOOLS

- Cordless Drill
- 3/8" Drill Bit or Step Drill
- 1" Hole Saw

Attach plusnuts in the holes.

TOOLS

- Plusnut Tool

HARDWARE USED

17x



94-130
Plusnut .250



2.3.3 Attach the top bracket to the van.

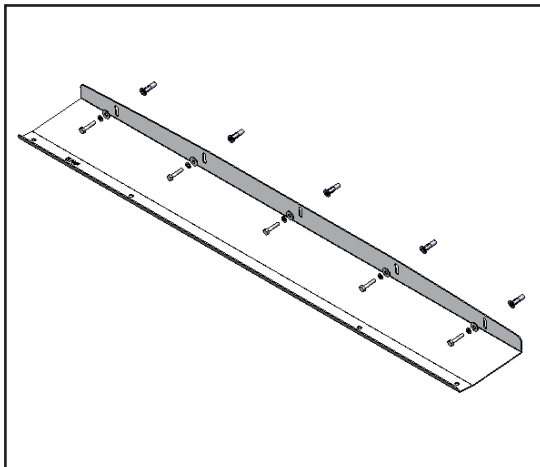
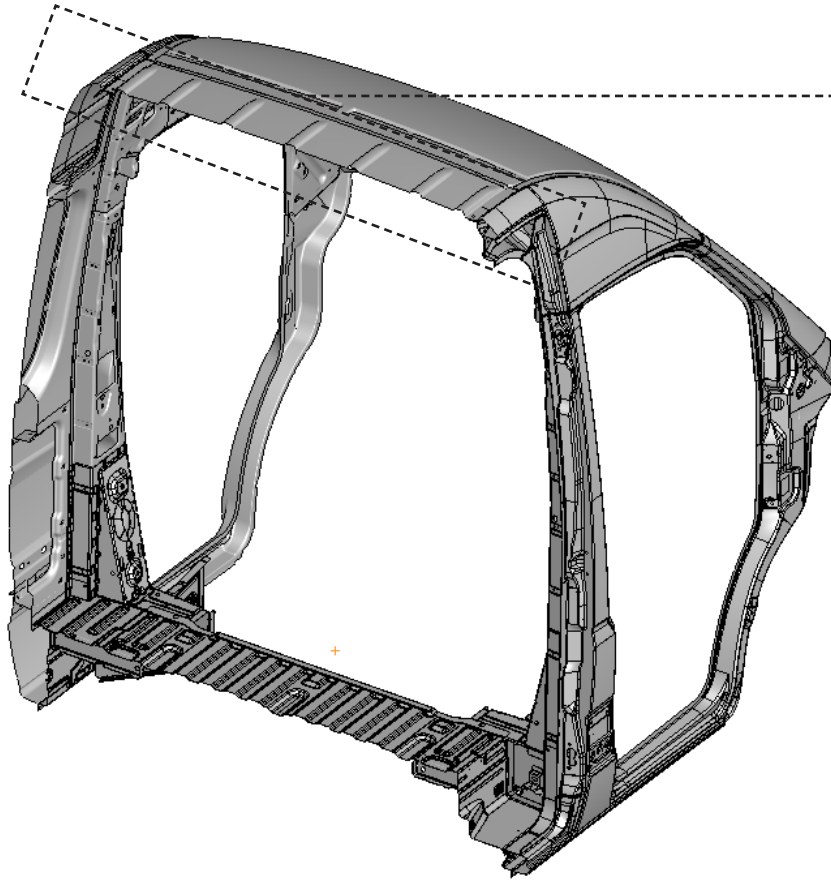

TOOLS

- Cordless Impact
- 7/16" Socket

HARDWARE USED

5x



#90-118 Hex Bolt 1/4" x 1-1/4"



#98-118 Lock Washer



#98-112 Flat Washer

2.3.4 Put the side panels in place, then bolt the driver and passenger side panels to the van.

NOTE: Put a bolt, lock washer, flat washer, 3 spacers and a retaining washer in the partition 1st, then attach the partition in the van.

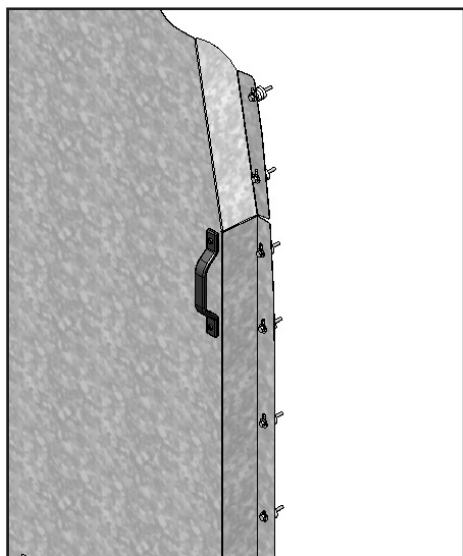
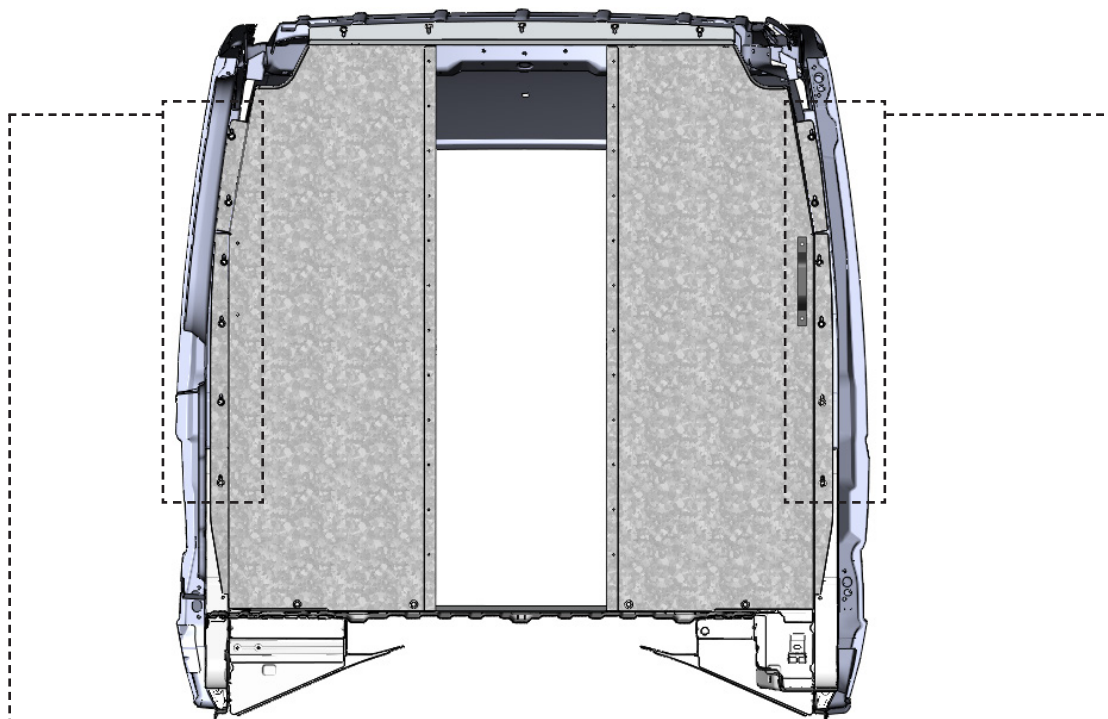

TOOLS

- Cordless Impact
- 7/16" Socket

HARDWARE USED

12x

- | | |
|---|----------------------------|
|  | #90-130 Hex Bolt 1/4" x 2" |
|  | #98-118 Lock Washer |
|  | #98-112 Flat Washer |
|  | #98-157 Spacers (3) |
|  | #98-158 Retaining washer |

2.3.5 Attach the driver and passenger side panels to the top bracket.

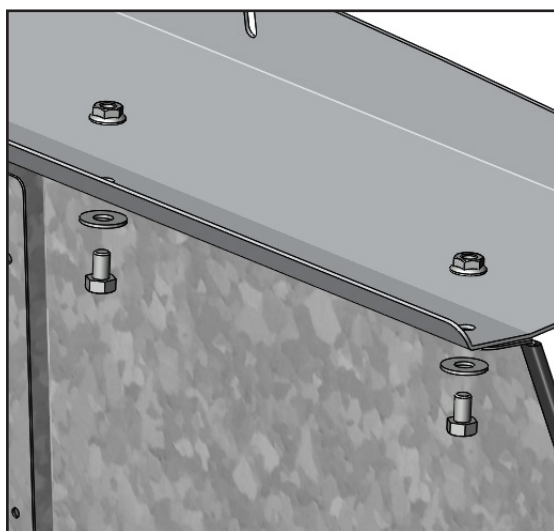
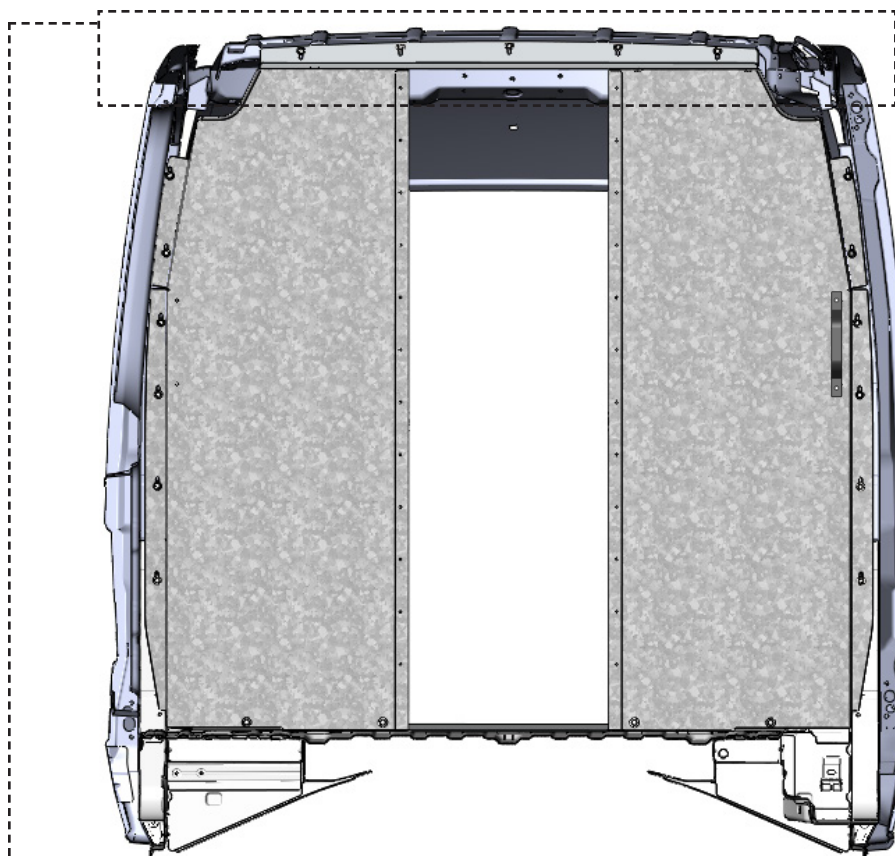



TOOLS

- Cordless Impact
- 1/2" Socket

HARDWARE USED

4x

- | | |
|---|-------------------------------|
|  | #90-200 Hex Bolt 5/16" x 1/2" |
|  | #98-116 Flat Washer |
|  | #94-116 Serrated Nut |

2.3.6 Attach the driver and passenger side panels to the floor bracket.

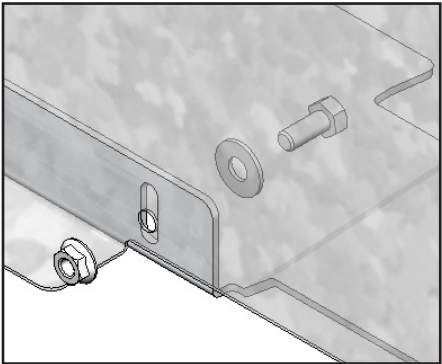
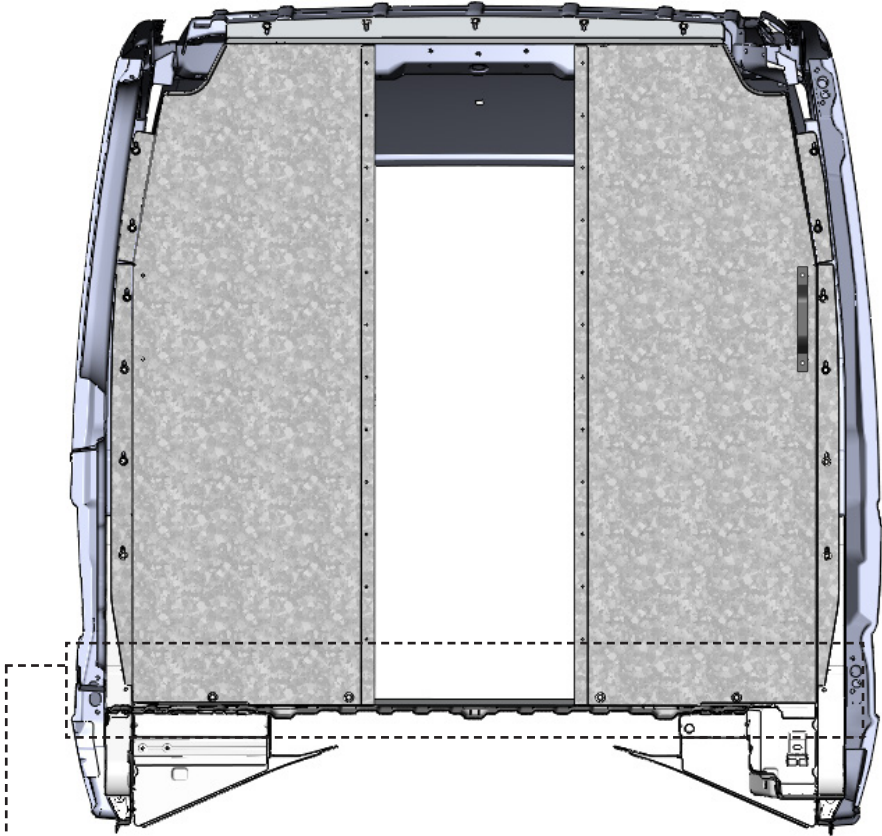



TOOLS

- Cordless Impact
- 1/2" Socket

HARDWARE USED

4x

-  #90-204 Hex Bolt 5/16" x 3/4"
-  #98-116 Flat Washer
-  #94-116 Serrated Nut

2.3.7 Apply the warning label on the passenger side panel.

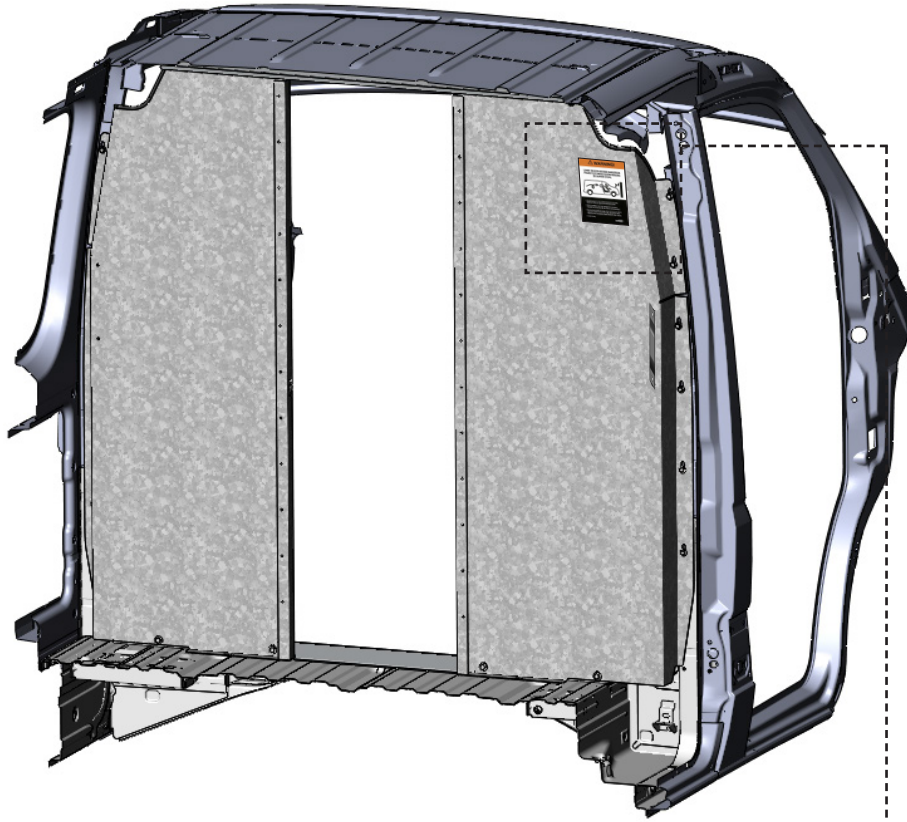

NOTE: English warning label is already attached on the passenger panel.



**“Congratulations, you have successfully installed your
Straight Partition!”**

Thank you for doing business with us.”

